

Analogue Rescaling Module

Features

- Field selectable ranges
- Reverse or normal output
- 24Vac/dc powered

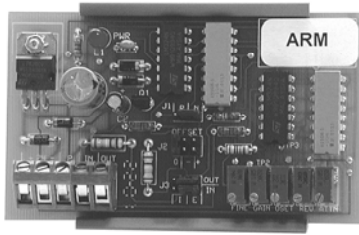

Specification

Input signal:

| | |
|------------|---|
| Voltage | 0 to 35Vdc max. |
| Current | 0 to 44mA max. |
| Input imp. | 1MW (Voltage input) 250W (Current input) |

Output signal:

| | |
|-------------|--|
| Voltage | 0.25 to 20Vdc max. |
| Current | 1 to 44mA max. |
| Output imp. | 3K3W @ 20Vdc min. voltage output 400W @ 10Vdc min. voltage output 750W max. current output |

Power supply 24Vac/dc ($\pm 10\%$) 200mA max.

Electrical Terminals for 0.5-2.5mm² cable

Connections Rising cage

Ambient range:

| | |
|-------------|--------------------------|
| Temperature | 0 to 50°C |
| RH | 10 to 95% non-condensing |

Dimensions 93 x 60 x 40mm

Country of origin China

Product Codes

IO-ARM

Analogue rescaling module

Technical Overview

The IO-ARM can accept either a voltage or current input, which can be converted and /or rescaled to a voltage or current output. The IO-ARM can also be used to reverse an input signal.

Installation

1. The IO-ARM should only be installed by a competent, suitably trained technician.
2. Ensure that all power is disconnected before carrying out any work on the IO-ARM.
3. Maximum cable is 2.5mm², care must be taken not to over tighten terminals.
4. When mounting the IO-ARM care should be taken not to stress the PCB when fitting to the DIN rail. If it is necessary remove the module from the DIN rail, be sure to use a flat bladed screwdriver to release the DIN clips.
5. The IO-ARM is designed to operate from a 24Vac/dc supply. In either case one side of the supply is common to the signal ground from the BEMS controller.
6. If the power supply is shared with other devices such as relay coils, solenoids etc., each coil must have a MOV or similar spike snubbing device fitted, or have a diode placed across the coil. The cathode of the diode must connect to the positive side of the supply.

Factory Default Settings

The unit is factory calibrated, with the following settings as defaults:

- No attenuation to the input signal
- Voltage input signal
- Voltage output signal
- Normal output action
- No offset to output signal
- Output signal gain of 1

NB: The IO-ARM does NOT isolate the input signal from the output signal.

Jumper Settings

Output action (J1):



Reverse acting Normal acting

Offset link setting (J2):



No offset



Negative offset



Positive offset

Output signal settings (J3):

I E



Output Current
Input Current



Output Voltage
Input Current



Output Current
Input Voltage



Output Voltage
Input Voltage

Connections

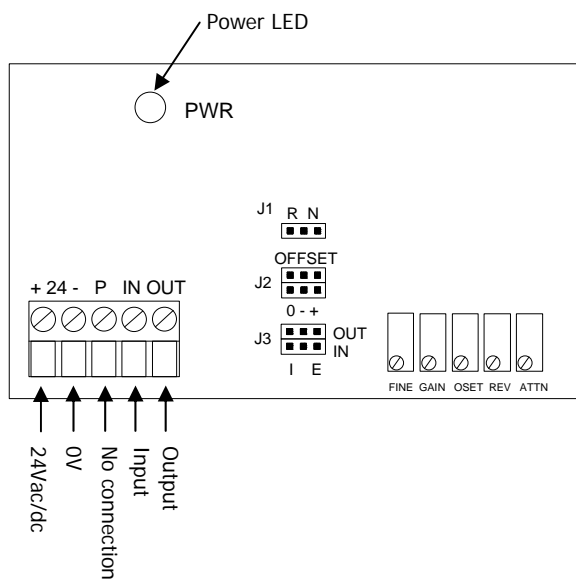

Quick Calibration Hints

The unit can be set up for common configurations as follows.

1. Trim potentiometer factory defaults:

| | |
|---------------------|-------------------------|
| Fully clockwise | FINE, GAIN, OFFSET, REV |
| Fully anticlockwise | ATTN |
2. Make the power, input and output connections as shown. Ensure the input and output have a common 0V.
3. Apply power. The PWR LED should light.
4. Typical Settings:
 - 4a/ Convert 0-10Vdc to 4-20mA
 - Ensure that the GAIN, FINE, OFFSET, REV and ATTN pots are as point 1. (factory set)
 - Ensure J1 is set to Normal
 - Ensure J2 is set to No offset
 - Ensure J3 is set to Voltage input & Voltage output
 - Apply 10Vdc to the input
 - Check the output voltage. If the output is above 4Vdc adjust the ATTN pot until the output is 4Vdc. If the output is lower than 4Vdc adjust the GAIN & FINE pots until the output is 4Vdc
 - Set J2 to Positive offset
 - Adjust the OFFSETT pot for an output of 5Vdc
 - Apply 0Vdc, and the output should be 1Vdc
 - Set J3 to Voltage input & current output
 - 4b/ Convert 4-20mA to 0-10Vdc
 - Ensure that the GAIN, FINE, OFFSET, REV and ATTN pots are as point 1. (factory set)
 - Ensure J1 is set to Normal
 - Ensure J2 is set to Negative Offset
 - Ensure J3 is set to Current input & Voltage output
 - Apply 4mA to the input.
 - Adjust the OFFSET pot for an output of 0Vdc
 - Apply 20mA to the input.
 - Adjust the GAIN pot for an output of 10Vdc
 - 4c/ Convert 0-10Vdc to 8-2Vdc
 - Ensure that the GAIN, FINE, OFFSET, REV and ATTN pots are as point 1. (factory set)
 - Ensure J1 is set to Reverse
 - Ensure J2 is set to Negative Offset
 - Ensure J3 is set to Voltage input & Voltage output
 - Apply 0V to the input.
 - Adjust the REV pot for an output of 8Vdc
 - Apply 10Vdc to the input.
 - Adjust the ATTN pot for an output of 2Vdc

Calibration

Complete the following steps to change the calibration of the IO-ARM. You will need a digital volt/current meter, a 24Vdc power supply and a voltage input signal simulator. (A 5K ohm or greater trim pot can be used as a voltage input signal simulator by connecting one end of the trim pot resistance winding to the (+) 24 of the power supply, the other end of the trim pot resistance winding to the (-) 24 of the power supply and the wiper end of the trim pot to the "IN" terminal of the IO-ARM.)

EQUIVALENT CALIBRATION VOLTAGE

Use a voltage signal for your input signal during calibration: this makes both the procedure and the explanation easier. If you will require a current input when you are finished, use the equation below to find the equivalent calibration voltage to use during the calibration procedure:

Equivalent Calibration Voltage = Required Input Signal Amps x 250

For example, 1 VDC is the equivalent calibration voltage for a 4 milliamp input signal ($1 = .004 \times 250$) or 5 VDC is the equivalent calibration voltage for a 20 milliamp input signal ($5 = .020 \times 250$).

Step 1) Trim Pot Presets

Set all pots as follows to start (These are 25 turn trim pots with no hard stops; they may make a slight clicking sound at either end of their range):

Turn the following pots full clockwise:

GAIN = gain of 1

FINE

OFFSET = 0 volts offset

REV = 0 volts reverse

Turn the following pot Full Counter clockwise:

ATTN = no input signal attenuation)

Step 2) Jumper Shunt Presets

J1- NORMAL OR REVERSE ACTING:

Set in "N" position for direct acting output signal. (If you require a reverse acting output signal, you will set this shunt in the "R" position in Step 7).

J2 - OFFSET:

Set in the "O" position for no offset to the output. (If you will require a "+" or "-" offset, you will set this shunt in the appropriate position in Step 6).

J3 IN - INCOMING SIGNAL VOLTAGE OR CURRENT:

Set in "E" position for voltage input. (If you require a current input, you will set this shunt in the "I" position **AFTER** you are finished with the calibration procedure).

Calibration (continued)

J3 OUT - OUTGOING SIGNAL VOLTAGE OR CURRENT:

Set in "E" position for voltage output.

(If you require a current **output**, you will set this shunt in the "I" position **AFTER** you are finished with the calibration procedure).

Step 3) Wiring Connections.

Make the following connections with the power OFF:

Connect a 24 volt AC or DC power supply to the ARM terminals "+24" and "-24".

Connect the input signal common (-) and the (-) meter lead to the "-24" terminal. Connect (+) input signal lead to the "IN" terminal. Connect (+) meter lead to the "OUT" terminal.

Step 4) Power Up

Turn on the 24 volt power supply: the POWER indicator will light.

Step 5) Input/Output Signal Adjustments

In this step you will figure the desired voltage input signal span and the desired voltage output signal span (see the section on Equivalent Calibration Voltage) and calibrate the IO-ARM to these input and output signal spans.

To calculate the voltage input signal span, subtract the minimum voltage input signal from the maximum input signal (i.e. a 0 to 5 volt input signal will give you a 5 volt input signal span: $5-0=5$).

To calculate the voltage output signal span, subtract the minimum voltage output signal from the maximum voltage output signal (i.e. a 3 to 15 volt output signal will give you a 12 volt output signal span: $15-3=12$).

Take the number for the voltage input signal span and apply this voltage to "IN" terminal.

Compare the output voltage reading on your meter with the voltage output signal span you calculated above. If the meter reading is higher, adjust the "ATTN" trim pot until the meter reading drops to the calculated output span. If the meter reading is lower, adjust the "GAIN" and "FINE" trim pots until the meter reading increases to the calculated output signal span.

Calibration (continued)

Step 6) Offset Adjustments

The offset adjustments simply shift the output signal range up or down from a "no offset" condition.

For example, an output signal range in a "no offset" condition is 3 to 15 volts. Adding an offset of 2 volts will now make the output signal range 5 to 17 volts. Subtracting an offset of 2 volts will now make the output signal range 1 to 13 volts.

Apply the minimum voltage input signal and read the minimum output signal on the meter. With the "OFFSET" jumper shunt "J2" in the "NO" position (from Step 6) no offset voltage will be added or subtracted from the output signal range.

If you need to shift the output signal range up, set the "OFFSET" jumper shunt "J2" in the "+" position and adjust the "OFFSET" trim pot until you increase the voltage reading on the meter to match the desired minimum output voltage. (Remember, this also increases the maximum output signal by the same amount.)

If you need to shift the output signal range down, set the "OFFSET" jumper shunt "J2" in the "-" position and adjust the "OFFSET" trim pot until you decrease the voltage reading on the meter to match the desired minimum output voltage. (Remember, this also decreases the maximum output by the same amount.)

Step 7) Reverse Action Adjustments

If you will require your output signal to reverse act, set jumper shunt "J1" in the "R" position. Apply the minimum voltage input signal and adjust the "REV" trim pot for the highest desired output signal.

Check the low, mid-scale and high signal points to insure proper calibration.

Step 8) Final Adjustments

If you require a current input, set the "J3" IN jumper shunt in the "I" position. If you require a current output, set the "J3" OUT jumper shunt in the "I" position. Check operation of the IO-ARM for desired signal rescaling and operation.

Calibration Worksheet

Fill in and circle answers.

1. Input: minimum_____maximum_____ mA or VDC, Output: minimum_____maximum_____ mA or VDC
2. Is the input Vdc? Yes/No. Is the output Vdc? Yes/No
 - a) If yes to both, set jumper J3 (IN/OUT) to E and skip to step 5.
 - b) If no to both, set jumper J3 (IN/OUT) to I and skip to step 5.
 - c) If yes to only one, continue to step 3.
3. Is current the input signal? If no, skip to step 4. If yes, perform the following:
 - a) Set J3 (IN) to I and (OUT) to E.
 - b) Multiply input minimum by 250 and enter value in "Input minimum" in step 5a.
 - c) Multiply input maximum by 250 and enter value in "Input maximum" in step 5a.

Example: minimum=4mA = $.004 \times 250 = 1$ Vdc and maximum=20mA = $.020 \times 250 = 5$ Vdc.
4. Is voltage the input signal. If no, skip to step 5. If yes,
 - a) Set J3 (IN/OUT) to E. Output jumper will be changed to I in later steps.
 - b) Multiply output minimum by 250 and enter value in "Output minimum" in step 5b,
 - c) Multiply maximum by 250 enter value in "Output maximum" in step 5b.

Example: minimum 4mA = $.004 \times 250 = 1$ Vdc and maximum 20mA = $.020 \times 250 = 5$ Vdc.
5. Enter mA, Vdc or equivalent values below. **Note:** Do not mix voltage and current.
 - a) Input minimum_____ Input maximum_____ maximum-minimum = Input span_____
 - b) Output minimum_____ Output maximum_____ maximum-minimum = Output span_____
6. Preset trim pots: Turn 20 times or until it clicks.
Turn Clockwise - Gain, Fine, Offset and Reverse
Turn Counter clockwise – Attenuation
7. Make all connections including signal generator and multi-meter. Apply power (24Vac or Vdc).
8. Set jumpers J2 to 0 and J1 to N
9. First test: input a 50% signal. Is the input equal to or close to the output?
If yes, proceed to step 10.
If no, return to step 7.
Note: Min, max and span values are found in step 5.
10. Supply the "input span" signal or equivalent to the input. (Refer to step 5).
 - a) If the "input span" is less than "output span", turn the gain or fine trim pot until the output is equal to the "output span" signal.
 - b) If the "input span" is greater than "output span", turn the attenuation trim pot until the output is equal to the "output span" signal.
11. Setting the offset jumper:
 - a) If the "input minimum" is greater than "output minimum" Set J2 to (-). Skip to 12.
 - b) If the "input minimum" is less than "output minimum" Set J2 to (+). Skip to 12.
 - c) If the "input minimum" is equal to "output min" Leave J2 alone and skip to step 12.
12. Supply the "input minimum" signal or equivalent to the input. Adjust the offset trim pot until the output reads the same as "output minimum".
13. Is signal reverse acting? If not skip to step 14. If yes, refer to following:
 - a) Set J1 to R.
 - b) Supply "input minimum", or equivalent, and adjust the Rev trim pot until reading is equal to output maximum.
14. If the output is current. Set J3 (out) to I and reset meter to current. ($V_{out} / 250 = \text{mA}$).
15. Check the low, mid-scale and high signal points to check output for proper calibration. Fine calibration adjustments may be made now.