

## 3-Phase 27kW Heater Controller



### Features

- 0-5Vdc or 0-10Vdc Control input
- Over temperature protection with auto reset
- No additional heatsinks required

### Specification

Input signal	0-10Vdc or 0-5Vdc
Supply (control)	24Vac/dc $\pm 10\%$ (by dipswitch)
Supply (load)	3-Phase 400V RMS $\pm 10\%$ 50/60Hz
Power /current ratings	27kW (38A per phase)
Fusing	40A High speed semiconductor type ferrule fuse (integral)
Terminal connections:	
Auxiliary alarm	Rising cage for 2.5mm <sup>2</sup> cable max.
Control	Rising cage for 2.5mm <sup>2</sup> cable max.
Power	Rising cage for 10mm <sup>2</sup> cable max.
Terminal torque setting	1.2Nm (only required for power terminals)
Over temperature:	
Trip in temp.	@ 90°C $\pm 1^\circ\text{C}$
Trip out temp.	@ 85°C $\pm 1^\circ\text{C}$
Fault condition	Relay rated at 125Vac @ 2A
Fault status:	
Phase loss	LED flashes in 1.5 sec. pulse bursts
Sensor loss	LED flashes in 0.5 sec. pulse bursts
Ambient temperature	65°C (maximum operational)
Fixing centres	4 x 5.5mm $\varnothing$ holes on centres 220mm (w) x 130mm (D)
Dimensions (L, W, H)	150 x 240 x 100mm
Conformity	CE Marked
Country of origin	UK

### Product Codes

#### RE-PR3-E-27

Panel mount 3-phase 27kW electric heater controller

Replacement fuse:

#### RE-PR3-F11510

40A High speed semiconductor ferrule type fuse



#### PLEASE NOTE:

The RE-PR3-E-27 is factory set for a internal 24V supply, if an external supply is used the dip switch SW3 **must** be changed before power-up.

## SAFETY REQUIREMENTS & ADVICE SHEET

### Introduction

The objective of this leaflet is to provide information to ensure that the safety of the person(s) installing or maintaining the equipment is not compromised and its location and method of installation does not endanger others, either during or after installation.

Customers should be aware of the Health and Safety at Work Act 1974 (HSW 1974) and the EC "Provision and Use of Work Equipment Regulations 1992" (PUWER). Both are available from the Health and Safety Executive (HSE) publications, within the UK.

### Installation

#### CE Directives

These are European regulations which apply to our industry. They affect the equipment emissions and immunity to Radio Frequency Interference (RFI) and various elements of safety for electrical equipment.

The European Community 'CE' Directives that mainly concern Sontay Ltd are, the Low Voltage Directive (LVD) and the Electromagnetic Compliance Directive (EMC).

A Declaration of Conformity may be supplied with the product or supplied on request.

#### Torque Settings

Good working practises must be adhered to ensuring appropriate electrical and mechanical installation. This would include the mechanical fixing of potentiometer bushes and electrical set screw and/or pillar connections. These Electrical Connections and Mechanical Fastenings must not be over tightened. We would recommend a typical torque setting of 1 to 5Nm. For specific product information, see appropriate product data sheet, where applicable.

#### Cooling Requirements

The use of an additional heatsink (this could be a conductive panel) suitably attached or mounted with the unit, will help to dissipate heat away from the device(s). An alternative or additional method would be forced air-cooling (using a fan), to assist the natural convection of airflow over an existing heatsink within the unit. The product fins should be mounted in line with the forced and/or natural airflow.

The equipment's environment and its initial ambient temperature also need to be considered, as this could have an adverse effect on the overall operating conditions.

### Fusing

We recommend that semiconductor, fast acting to BS88 IEC 269, type fuses or circuit breakers (Semiconductor - MCB) should be used for unit and/or device protection. The appropriate maximum load current should be known to select the required SCR fuse or Z curve MCB, but must not exceed the equipment rating. The  $I^2 t$  ( $A^2 s$ ) rating of the selected fuse must be less than that of the equipment so as to protect the equipment's discrete device. Further appropriate fusing may be required for protection of the unit supply using standard fuse links and holders. Failure to address these requirements and the use of incorrectly selected fuses may cause the equipment to fail.

### Earthing

The protective conductor terminal of the equipment must be utilised at all times and bonded to a 'good' Earth (ground). The earth bonding (strapping) leads of any combined equipment should be as short as possible and be substantial, i.e. at least rated higher than the equipment's load. For further information, refer to BS7671. Following these simple guidelines will ensure optimum use of any appropriate filter circuits which may be required.

### Insulation (over-voltage category) and Protection from electric shock Classification of Equipment

All equipment, unless otherwise stated, is rated to CLASS II Insulation (Over-voltage category) and CLASS I (Protection category).

### Maintenance

Before any servicing is carried out, reference should be made to appropriate installation instructions, drawings and labelling which may come with the equipment. Personnel should switch off the unit supply before accessing or removing any safety cover and be aware of hazardous live parts.

## Technical Overview

The RE-PR3-E-27 is a Triac control assembly that provides full seamless control of 3-phase resistive loads up to 27kW, using two thirds control technique. They are controlled by a 0-10Vdc or 0-5Vdc signal.

This burst fire control assemblies use fast pulse, zero volt, switching technology to minimise flicker and eliminate RFI problems.

They also incorporate a temperature trip, automatic reset, alarm output, LED 'output on' indication and heatsink.

Applications include electric heater batteries and duct heaters.

## Location & Ventilation

The RE-PR3-E-27 power controller is designed for mounting on a vertical panel, with the heatsink fins to the bottom. It is important that free air movement around the heatsink is not restricted. Allow sufficient air space between adjacent units to allow optimum performance of the heatsink.

The maximum ambient of 65°C should not be exceeded. Where necessary control panels & enclosures should be ventilated with a fan.

## Load Considerations

The RE-PR3-E-27 series of power controllers are designed for resistive type loads only. Capacitive, or unusual heating loads such as Molybdenum, Platinum or Tungsten, (which can have a 10:1 hot to cold resistance ratio) are not suitable.

## Over Temperature Monitoring

The RE-PR3-E-27 is fitted with a thermal protection device to protect against over temperature. The unit will automatically switch off the load in the event of the heatsink temperature exceeding safe limits (90°C ±1°C). Once the temperature has fallen to a safe level (85°C ±1°C) the load will be switched on again if the supply is still present.

Under normal operating conditions the heatsink will not reach 90°C but this might occur, for example when the ambient temperature exceeds 65°C.

**Caution:** During the course of normal operation metal parts, in particular the heatsink, may get very hot.

## Control Supply

The RE-PR3-E-27 is factory set for a internal 24V power supply.

If using an external 24Vac/dc supply you must change the DIP switch SW3 on the PCB prior to applying power. This is polarity independent.

If there is a requirement for the alarm relay and LED to energise when any of the 3 phases fails, the external, isolated 24Vac/dc supply option must be used.

## Earth Connection

The RE **MUST** be earthed. A protective earth connection is provided in the main terminal connections.

## Back-Up Protection & Load Supply

The RE-PR3-E-27 is protected by internal quick acting semi-conductor type fuses.

Load cables must be sized such that they are rated in excess of the fuse ratings.

It is recommended that a load break switch and a contact breaker is installed in the load supply. The supply to the contactor coil should be interrupted by an over-temperature thermostat located in the heater battery and also upon detection of airflow loss.

## Fault conditions

The factory default setting of DIP switch SW1 is the ON position. In this position, the alarm relay will be energised only when a fault condition occurs.

Changing SW1 to the OFF position will cause the alarm relay to be energised continuously until a fault condition occurs.

If the internal 24V supply is used, a fault condition will occur on over temperature or if the L3 phase only is missing. If an external 24V supply is used, a fault condition will occur on over temperature, temperature sensor failure, or if any of the 3 phases are missing.

Should the 24V supply fail the output of the unit will fail to OFF with no output.

### Phase Loss With Auxiliary Supply

When any one of the three phase inputs are missing, the relay changes state and the LED flashes ON/OFF bursts of 1.5 seconds.

Note - This is only true when using an external 24V supply.

When using an external supply the 3-phase power must be turned on before the external (24V) control supply. If the control supply is turned on first, then it will go into phase failure, due to the 3-phase being off.

### Alarm relay

The alarm relay has contacts rated up to 8A @ 230Vac (RMS) load. Where the internal 24V supply is used, the relay obtains its supply from the transformer via two 20mm 1A fuses, and are connected to the L1 and L2 phases. Therefore the alarm relay can only change state when there is an over-temperature condition, a sensor fault, or if the L3 phase only is missing.

### Manual control

The units output can be controlled manually by using a 5k $\Omega$  linear potentiometer connected as shown on page 4, **with the input signal set to 5Vdc (SW4)**.

**Note:** A 5k $\Omega$  linear potentiometer MUST NOT be connected at same time as an external control signal.

### Installation

1. The RE-PR3-E-27 should only be installed by a competent, suitably trained technician, experienced in installation with hazardous voltages. (>50Vac & <1000Vac or >75Vdc & 1500Vdc)
2. Ensure that all power is disconnected before carrying out any work on the RE-PR3-E-27.
3. Maximum cable size is 2.5mm<sup>2</sup> for control supply and 10mm<sup>2</sup> for phase power. Care must be taken not to over tighten terminals.

### Dip Switches

SW1 (relay status):

ON = Standard

OFF = Reverse

SW3 (remote supply):

INT = Uses internal transformer

EXT = External 24V supply

SW4 (control signal):

OFF= 0-10Vdc signal

ON = 0-5Vdc signal

Connections

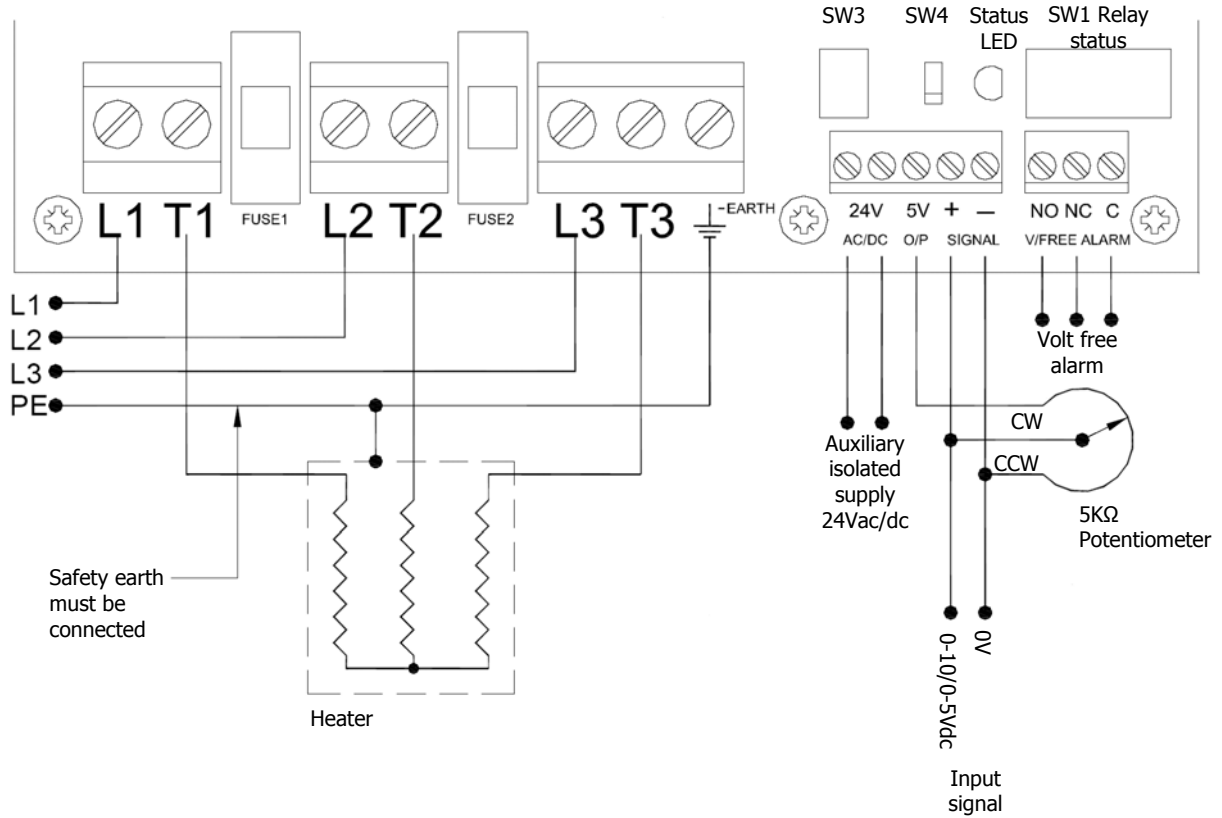

Star configuration:

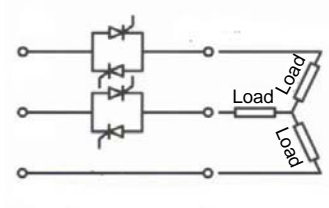

Delta configuration:

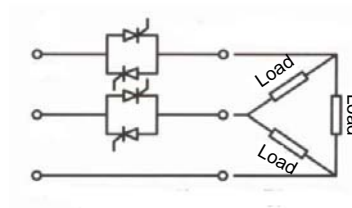

**⚠ WARNING!** Do not connect neutral to star point of heater.