

Space Mount RH & T Sensors



Features

- High stability and reliability
- No loss of accuracy up to 100% RH
- Built-in circuitry diagnostics
- $\pm 2\%$ and $\pm 3\%$ Accuracy versions
- 4-20mA or 0-10Vdc outputs (link selectable)

Specification

RH accuracy:	
RH-SP01	$\pm 2\%$
RH-SP02	$\pm 3\%$
Long term stability	< 2% RH p.a.
Temp. accuracy	$\pm 0.3^\circ\text{C}$
Outputs	4-20mA or 0-10Vdc
Output ranges:	
RH	0 to 100%RH
Temperature	0 to $+40^\circ\text{C}$ (others on request -TR)
Enthalpy	-20 to $+269\text{kJ/kg}$ (optional)
Dewpoint	-40 to $+60^\circ\text{C}$ (optional)
Power supply:	
4-20mA	20 - 35Vdc for 500 Ω loop resistance
0-10Vdc	17 - 34Vdc, or 14 to 26Vac (4.7K Ω min)
Connections	0.5 - 2.5mm ² cable
Housing Material	ABS (flame retardant)
Dimensions	85 x 85 x 23mm
Ambient range	-10 to $+50^\circ\text{C}$
Country of origin	UK

Product Codes

RH-SP01

Space RH & T transmitter, $\pm 2\%$ accuracy

RH-SP02

Space RH & T transmitter, $\pm 3\%$ accuracy

-EN

Enthalpy & dewpoint outputs (Only available with the RH-SP01)

-TR

Custom temperature range (available on request)

-LCD

Integral LCD display for RH & Temperature

Technical Overview

The RH-SP space mounted humidity & temperature sensors offer the latest technology for high accuracy RH measurement. The RH-SP01 is also available with additional outputs for enthalpy and dewpoint (RH-SP01-EN). Non-standard temperature output ranges can be specified at time of order.

Installation

Antistatic precautions must be observed when handling these sensors. The PCB contains circuitry that can be damaged by static discharge.

1. Select a location on a wall of the controlled space which will give a representative sample of the prevailing room condition. Avoid sitting the sensor in direct sunlight.
2. Undo the tamperproof screw at the bottom of the housing and gently pull the front panel from the base.
3. Using the base as a template mark the hole centres and fix to the wall using suitable screws. Alternatively the base plate can be mounted onto a conduit box or a standard recess back box.
4. Feed the cable through the 22mm knockout in the housing base and terminate as required.
5. Set jumpers as required .
6. Leaving some slack inside the housing replace the front panel to the base plate.
7. Fit the tamperproof screw (if required) through the lug at the bottom of the base plate.
8. Ensure that the supply voltage is within the specified tolerances.
9. Allow 3 minutes before checking functionality.
10. Allow 30 minutes before carrying out pre-commissioning checks.

Note Standard units are factory set for 4-20mA outputs.

Connections & Jumpers

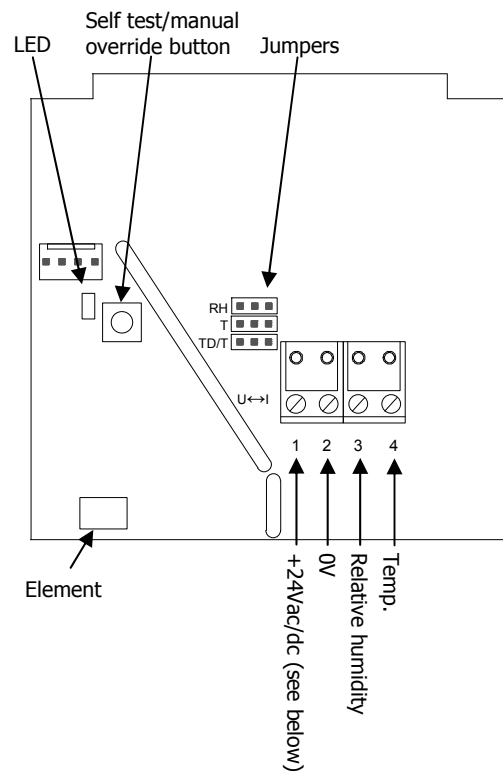

	RH = 4-20mA	RH = 0-10Vdc
	T = 4-20mA	T = 0-10Vdc
	Dew = 4-20mA	Dew = 0-10Vdc
	Ent = 4-20mA	Ent = 0-10Vdc
RH	Right	Left
T	Right	Left
T/TD	Right	Right
1	24Vdc	24Vac/dc
2	No connection	0V
3	RH output	RH output
4	T output	T output

Note. Enthalpy & dewpoint outputs are only available with the RH-SP01 (see page 5 for connection details).

Connection Examples

RH and Temp. = 4-20mA Loop powered
24Vdc from controller:

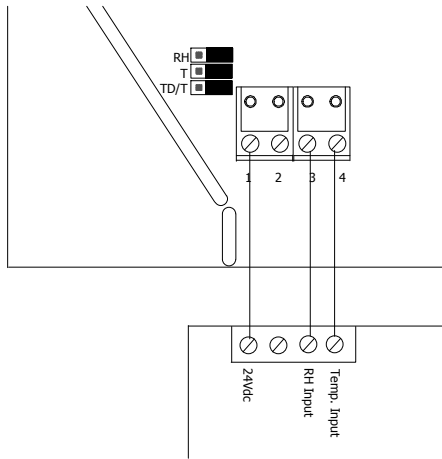

RH and Temp. = 4-20mA Loop powered
24Vdc from external 24Vdc supply:

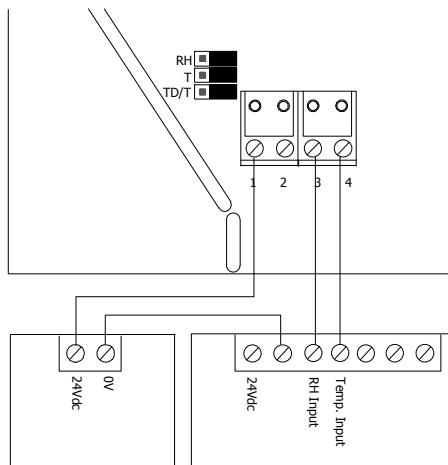

Connection Examples (continued)

RH and Temp. = 0-10Vdc
24Vdc from controller:

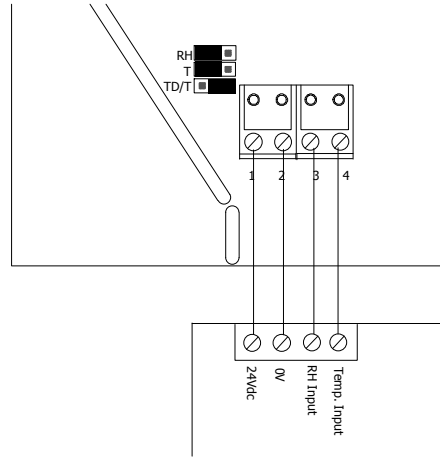

RH and Temp. = 0-10Vdc
24V from external 24Vac/dc supply:

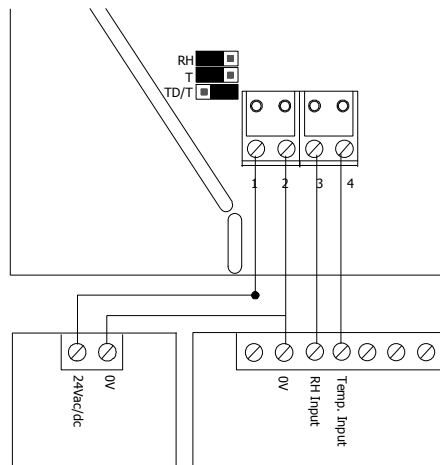

Self-Test & Manual Override Mode

The outputs of the RH-SP can be manually overridden to one of 3 values by pressing the PCB mounted button. When this button is pressed once, the outputs will change to 0% of the output's range, when pressed again the outputs will change to 50% of the output's range and when pressed a third time will change the outputs to 100% of the outputs range. Pressing again will return the outputs to automatic control.

Example:

- First Press – RH output falls to 0% and temperature output falls to 0°C, LED flashes slowly
- Second Press – RH output rises to 50% and temperature output rises to 20°C, LED flashes slowly
- Third Press – RH output rises to 100% and temperature output rises to 40°C, LED flashes slowly
- Fourth Press – RH and temperature outputs revert to automatic levels. The LED should be permanently on.

Failure Mode

If the sensor element assembly fails, the outputs will change to the following fixed default values and the LED will flash rapidly;

RH = 0%

Temperature = 21°C

Dewpoint (optional) = 10°C

Enthalpy (optional) = 50 kJ/kg

NB – When using the RH-SP01-EN enthalpy and dewpoint version in 4-20mA loop powered output mode, at least 2 of the loops must be powered before the unit will operate correctly.

Warning

Relative humidity transmitters are sensitive electronic devices and care should be taken at all times to ensure that they are not exposed to extreme ambient conditions or incorrect electrical connection. Transmitters should not be exposed to direct moisture contact (e.g. rain) and saturation of the transmitter at very high humidity should be avoided wherever possible.

Commissioning

To perform an accurate comparison between a transmitter output and a portable reference, it is essential that the two probes are held adjacent for a minimum of 30 minutes in a stable RH environment. Only in this way can speed of response and temperature factors be eliminated. It is not uncommon for test instruments and transmitters to disagree by 10% RH or more when site measurements are taken incorrectly. 'Slings' or other mechanical hygrometer should **not** be used as a reference.

Trend scaling

IQ1xx and early IQ2x series (without type 5, characterise),

4-20mA

(0 to +40°C)		(0 to 100%RH)	
Brange	-60	Brange	-150
Trange	40	Trange	100
Upper	40	Upper	100
Lower	0	Lower	0
Exp	3	Exp	3

0-10Vdc

(0 to +40°C)		(0 to 100%RH)	
Brange	-40	Brange	-100
Trange	40	Trange	100
Upper	40	Upper	100
Lower	0	Lower	0
Exp	3	Exp	3

IQ2xx and early IQ3 series (with type 5, characterise),

4-20mA

(0 to +40°C)		(0 to 100%RH)	
Upper	40	Upper	100
Lower	0	Lower	0
Exp	3	Exp	3
Points used	2	Points used	2
I1	4	I1	4
O1	0	O1	0
I2	20	I2	20
O2	40	O2	100

0-10Vdc

(0 to +40°C)		(0 to 100%RH)	
Upper	40	Upper	100
Lower	0	Lower	0
Exp	3	Exp	3
Points used	2	Points used	2
I1	0	I1	0
O1	0	O1	0
I2	10	I2	10
O2	40	O2	100

-EN Output Connections & Jumper Settings

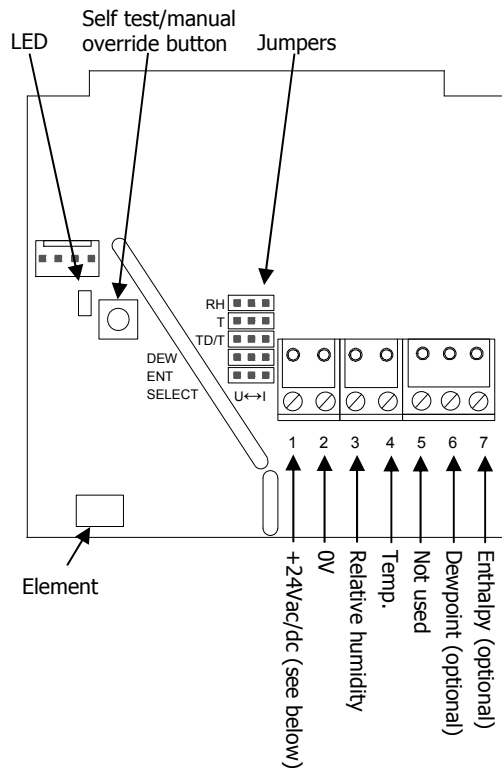

	RH = 4-20mA	RH = 0-10Vdc
	T = 4-20mA	T = 0-10Vdc
	Dew = 4-20mA	Dew = 0-10Vdc
	Ent = 4-20mA	Ent = 0-10Vdc
RH	Right	Left
T	Right	Left
T/TD	Right	Right
DEW	Right	Left
ENT	Right	Left
1	24Vdc	24Vac/dc
2	No connection	0V
3	RH output	RH output
4	T output	T output
5	No connection	No connection
6	Dew output	Dew output
7	Ent output	Ent output