

4-20mA/0-10Vdc Output Transmitter



Features

- Choice of outputs and ranges on one unit
- Temp. range selectable via jumper setting

Specification

Selectable output type:

0-10Vdc
4-20mA (loop powered)

Selectable output range depending on sensor type:

-10 to +40°C
-10 to +110°C
-10 to +160°C
0 to +400°C
Custom, in the range of -40 to +400°C (depending on sensor ambient range)

Supply voltage:

0-10Vdc	24Vac ±15% @ 50Hz or 24Vdc +15% -6%
4-20mA	24Vdc ±15% -6%

Accuracy:

TT-526 only

Transmitter	±0.2°C
PRT Element	±0.425°C @ 25°C
Overall	±1.0°C

Others

Transmitter	±0.2°C
PRT Element	±0.2°C @ 25°C
Overall	±0.4°C

Sensor type:

TT-526 only	PT100B
Others	D (PT100A)

Connectors Terminals for 0.5-2.5mm² cable

Ambient range:

Temperature	-10°C to 50°C
Humidity	0 to 80%RH, non-condensing

Country of origin UK

Product Codes

TT-518-CVO

Thimble sensor, selectable output

TT-522-CVO

Duct sensor, selectable output

TT-525-CVO

Duct averaging sensor, selectable output

TT-526-CVO

True duct averaging sensor, selectable output

TT-531-CVO

Outside air sensor, selectable output

TT-532-CVO

Outside air sensor c/w rad. shield, selectable output

TT-541-CVO

Immersion sensor, selectable output

TT-542-CVO

High temp. Immersion sensor, selectable output

TT-551-CVO

Strap-on sensor, selectable output

TT-555-CVO

Flying lead sensor, selectable output

TT-911-CVO

Space sensor, selectable output

TT-911-CVO-SP

Space sensor, selectable output and set point adjustment

TT-915-CVO

Black bulb sensor, selectable output

TT-xxx-CVO-C

Custom temperature scaling in the range of -40 to +400°C (dependent on sensor type, ambient and application)

Note:

Please see corresponding temperature datasheet for further specification and full installation instructions.

Technical Overview

The TT-CVO 'universal' temperature transmitter combines 4 pre-set ranges, selectable output modes and customised output range scaling. An active set point adjustment option is available (for space housing only).

Connections

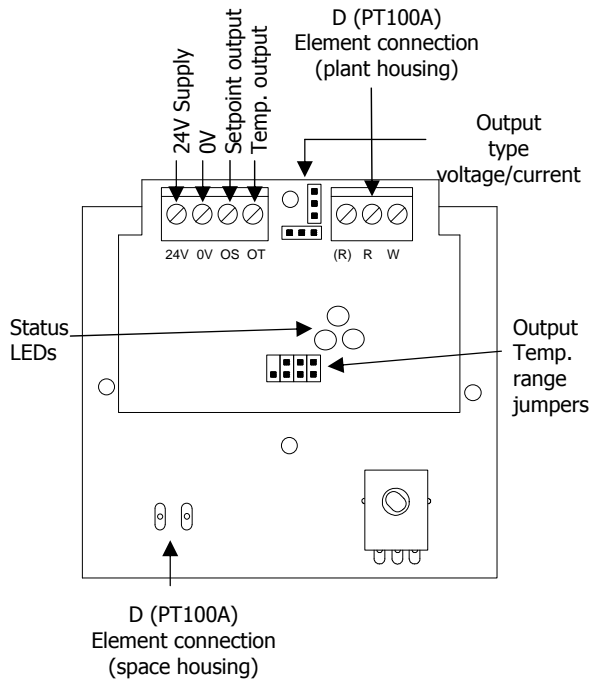

Current output

If using a current output mode, the sensor must **only** be used with a 24Vdc supply. The sensor may be damaged if supplied with AC.

Jumper Settings

Output Temperature Range Selection:

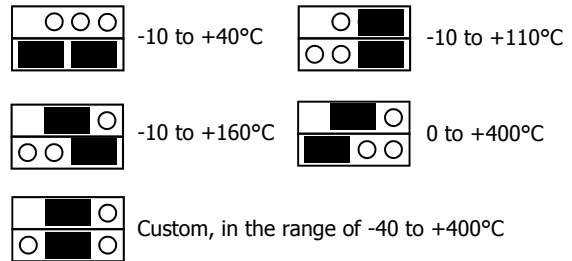

Note: If the range links are incorrectly set, or missing, the output range will default to -10 to +40°C

Output Signal Type:

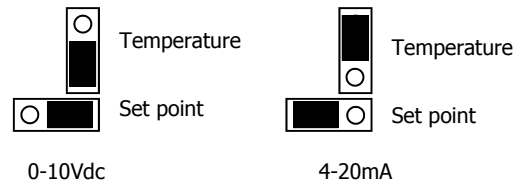

Note: There is one link for SP and one for T, which can be set independently from each other, allowing (for example) the temperature output as 0-10Vdc and set point option output as 4-20mA.

Connection Examples

Temp. = 4-20mA Loop powered, -10 to +110°C
 24Vdc from external 24Vdc supply:

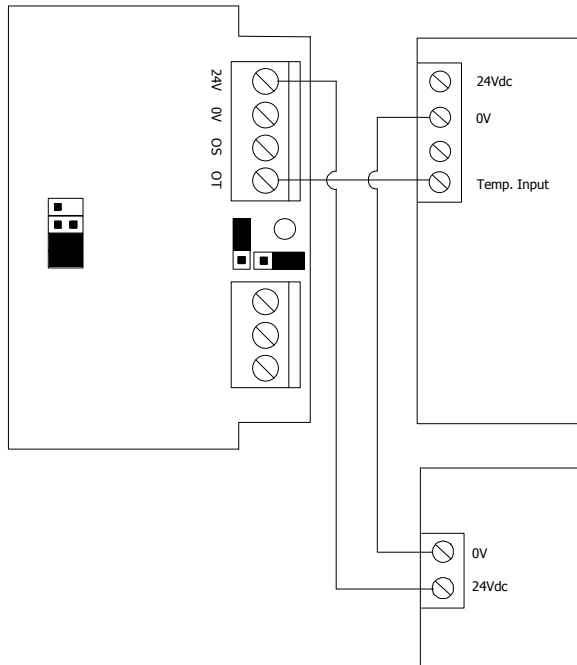

Temp. = 0-10Vdc, 0 to 400°C
 24V from external 24Vac/dc supply:

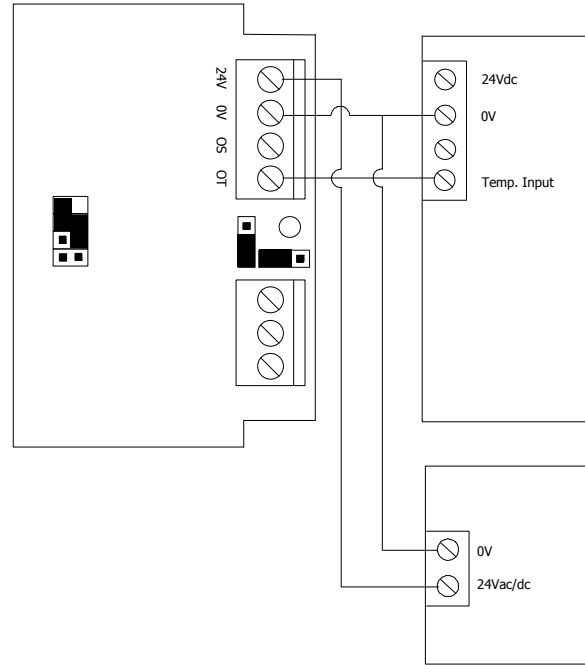

Temp. = 4-20mA Loop powered, -10 to +40°C
 24Vdc from controller:

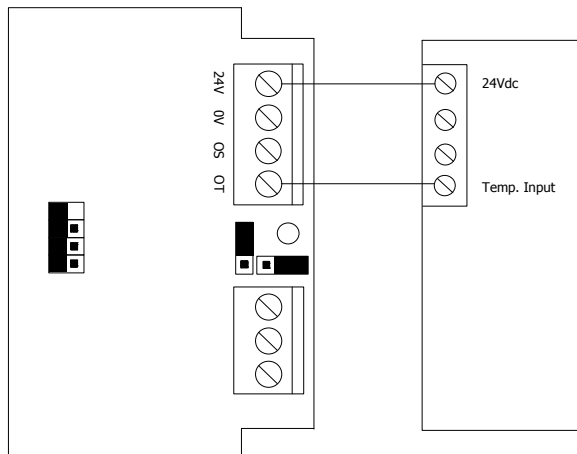

Temp. = 0-10Vdc, -10 to +40°C
 Set point = 0-10Vdc
 24Vdc from controller:

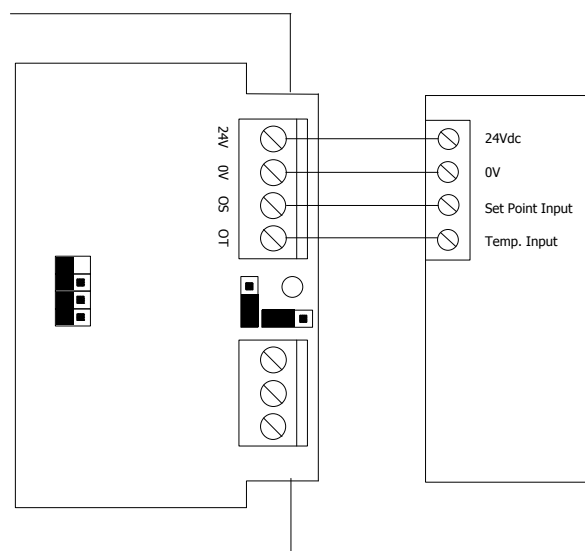

LED Status

Power supply

Normal:

The green LED indicates the supply condition. If the power supply is normal the green LED is ON continuously. This shows that the TT-CVO is powered correctly.

Low Supply Voltage:

If power supply falls below about 22V the green LED does double flashes twice a second;

*_*_*_*_*_*_*_*_*_*_*_*_*_*_*_*_**

The PCB tries to maintain the correct output but may be unable to achieve the specified voltage or current level. At very low voltages it will stop working.

High Supply Voltage:

If the power supply is above 40V the green LED flashes 6 times a second;

*_*_*_*_*_*_*_*_**

The PCB tries to maintain the correct outputs but components on the PCB may overheat causing unreliability and ultimately failure.

Output

4-20mA output:

The red LED is on when the PCB is in 4-20mA mode and working correctly. For this to be so these conditions must be met:

1. The output select jumper(s) must be set to the 4-20mA position.
2. The output load must be an impedance of 500Ω or less.
3. The PCB is capable of sourcing the correct output current. (The red LED may flash if the PSU is below 22V or the impedance is more than 500Ω).
4. If using a current output mode, the sensor must only be used with a 24V DC supply. The sensor may be damaged if supplied with AC.

0-10Vdc output:

The output select jumper(s) must be connected in the 0-10Vdc position, minimum impedance 2kΩ.

Trend Scaling

IQ1xx and early IQ2xx series (without type 5, characterise)

(-10 to +40°C)

4-20mA		0-10Vdc	
Brange	-85	Brange	-60
Trange	40	Trange	40
Upper	40	Upper	40
Lower	-10	Lower	-10
Exp	3	Exp	3

(-10 to +110°C)

4-20mA		0-10Vdc	
Brange	-190	Brange	-130
Trange	110	Trange	110
Upper	110	Upper	110
Lower	-10	Lower	-10
Exponent	3	Exponent	3

(-10 to 160°C)

4-20mA		0-10Vdc	
Brange	-265	Brange	-180
Trange	160	Trange	160
Upper	160	Upper	160
Lower	-10	Lower	-10
Exponent	3	Exponent	3

(0 to 400°C)

4-20mA		0-10Vdc	
Brange	-600	Brange	-400
Trange	400	Trange	400
Upper	400	Upper	400
Lower	0	Lower	0
Exponent	4	Exponent	4

IQ2xx and IQ3 series (with type 5, characterise)

(-10 to +40°)

4-20mA		0-10Vdc	
Upper	40	Upper	40
Lower	-10	Lower	-10
Exp	3	Exp	3
Points used	2	Points used	2
I1	4	I1	0
O1	-10	O1	-10
I2	20	I2	10
O2	40	O2	40

Trend Scaling (continued)

IQ2xx and IQ3 series (with type 5, characterise)

(-10 to +110°)

4-20mA		0-10Vdc	
Upper	110	Upper	110
Lower	-10	Lower	-10
Exp	3	Exp	3
Points used	2	Points used	2
I1	4	I1	0
O1	-10	O1	-10
I2	20	I2	10
O2	110	O2	110

(-10 to +160°)

4-20mA		0-10Vdc	
Upper	160	Upper	160
Lower	-10	Lower	-10
Exp	3	Exp	3
Points used	2	Points used	2
I1	4	I1	0
O1	-10	O1	-10
I2	20	I2	10
O2	160	O2	160

(0 to +400°)

4-20mA		0-10Vdc	
Upper	400	Upper	400
Lower	0	Lower	0
Exp	4	Exp	4
Points used	2	Points used	2
I1	4	I1	0
O1	0	O1	0
I2	20	I2	10
O2	400	O2	400